



RD-200C RD-200H

MOTOR GRADERS

EXTRA



■ **Net Horsepower**
133 kW (178 hp)

■ **Operating Weight**
16500 kg (36,376 lb)
16800 kg (37,037 lb)

RD-200C RD-200H MOTOR GRADERS

- Excellent visibility and operator comfort
- Efficient performance
- Ease of operation



ENGINE

* Make and Model	CUMMINS QSB 6.7
Type	In-line, 6-cylinder
Aspiration	Turbocharged and CAC
Fuel system	HPCR Electronic
Gross Horsepower, SAE J1995	142 kW (190 hp)
Net Horsepower, SAE J1349/ISO 9249	133 kW (178 hp)
Rated rpm	2400 rpm
Maximum torque @ 1500 rpm	929 Nm (685 lb-ft)
Displacement	6.7 l (409 in³)
Bore and Stroke	107 x 124 mm (4.2" x 4.9")
Air cleaner	2-stage, with service indicator

* Meets EU Stage IIIA and EPA Tier 3 emission regulations

TRANSMISSION AND TORQUE CONVERTER

Electronically controlled powershift transmission with integral torque converter provides 6 speeds forward and 3 reverse. Automatic or manual mode. Torque converter with optional lock-up system.

TRAVEL SPEEDS

Gear	Forward		Reverse	
	km/h	(mph)	km/h	(mph)
1 st	5.3	(3.3)	5.6	(3.5)
2 nd	8.1	(5.0)	13.5	(8.4)
3 rd	12.9	(8.0)	31.4	(19.5)
4 th	19.5	(12.1)	-	
5 th	29.9	(18.6)	-	
6 th	44.7	(27.8)	-	

FRAME

Material: construction steel, welded unit.	
Section	282 x 320 mm (11.1" x 12.6")
Wall thickness	20 mm (0.79")
Vertical section module, min.	2114 cm³ (129 in³)
Linear weight per length, average	270 kg/m (181 lb/ft)

FRONT AXLE

Wheel lean angle, left or right	22°
Oscillation, total	40°
Articulation, left or right	31°
Ground clearance at the center	550 mm (21.7")

REAR AXLE

Lug mounted, bevel gear with No Spin differential.

CIRCLE

Fabricated from heat treated carbon steel.	
Diameter (outside)	1350 mm (53.1")
Circle reversing control hydraulic rotation	360°

DRIVE SYSTEMS

RD-200C Tandem drive (4 wheels)

Oscillating, welded box section, oil tight housing	
Dimensions	1890x445x134 mm (74.4"x17.5"x5.3")
Axle spacing	1540 mm (61")
Tandem oscillation	17° forward, 17° reverse
Ground clearance	430 mm (17")

RD-200H All-wheel drive (AWD)

Additional front wheel drive, hydraulic.

STEERING

Hydraulic power steering system with emergency steering capability.	
Steering column, adjustable height and angle.	
Minimum turning radius	7500 mm (24'7")
Articulation, left or right	25°

BRAKES

Service - wet multidisc, hydraulic applied, two-circuit with gas accumulators, effective on four tandem wheels. Parking/Emergency - disc type, mounted on output shaft of the transmission

HYDRAULIC SYSTEM

Load sensing system including variable displacement axial piston pump, multisection control valve and hydraulic lock valves automatically matches flow and pressure requirements for reduced heat generation and increased hydraulic efficiency and fuel economy.

Hydraulic pump displacement	80 l/min (21 gpm)
Max. system pressure	140 bar (2030 psi)

CAPACITIES

	Liter	(US gal)
Fuel tank	380	(100)
Cooling system	40	(10.6)
Engine oil	16.4	(4.3)
Transmission	35	(9.2)
Rear axle	7.5	(2.0)
Tandem housing	2 x 30	(2 x 8)
Reservoir, hydraulic system	130	(34)
Reservoir, drive train (RD-200H)	55	(14.5)

INSTRUMENTATION

Indicators: brakes, transmission and operative condition, hand brake, flashlight, road and turn lights, transmission display: actual gear selected and error codes

Gauges: engine rpm, fuel level, engine coolant temperature, transmission oil temperature, battery charge, hourmeter (daily and actual hrs)

OPERATING WEIGHT

Includes standard equipment:	
- RD-200C	16500 kg (36,376 lb)
- RD-200H	16800 kg (37,037 lb)

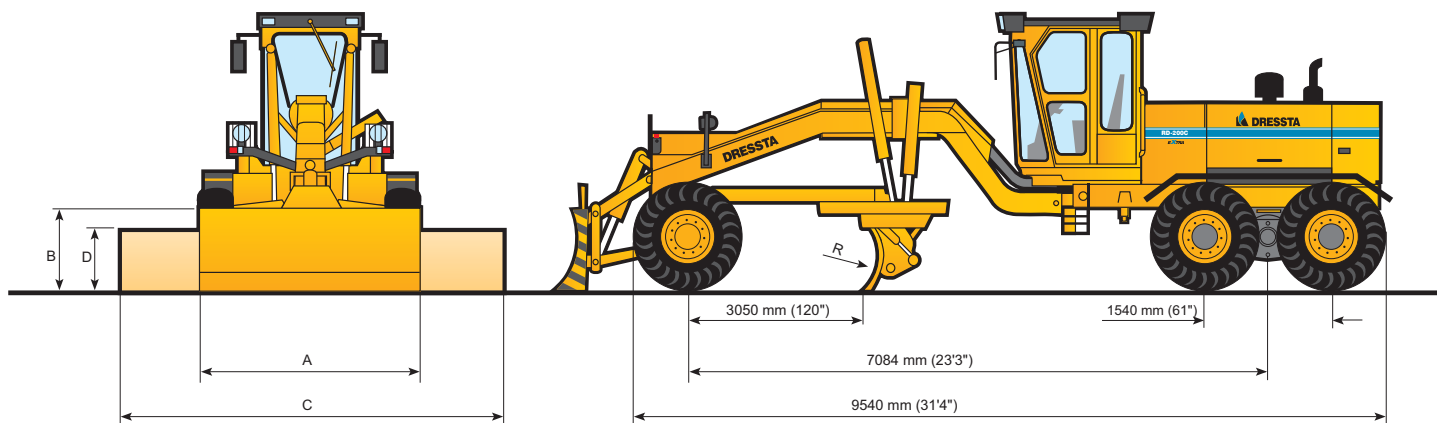

DIMENSIONS

Length, standard machine	9200 mm (30'2")
Length, machine equipped with ripper	10580 mm (34'9")
Length, machine equipped with front blade (dozer/angle)	10187/10267 mm (33'5"/33'8")
Length, machine equipped with ripper and front blade (dozer/angle)	11435/11515 mm (37'6"/37'9")
Width, tire center lines	2024 mm (6'8")
Width, outside tires	2500 mm (8'2")
Height, high profile cab	3380 mm (11'1")
Height, beacon light mtd	3590 mm (11'9")
Height to exhaust pipe	2950 mm (9'8")

MOLDBOARD

Blade width (C)	3660 mm (144")
Blade height (D)	670 mm (26.4")
Arc radius (R)	432 mm (17")
Blade thickness	22 mm (0.87")
Cutting edge thickness	19 mm (0.75")
End bits thickness	22 mm (0.87")
Sideshift, RH/LH	800 mm (31.5")
Full circle rotation	360°
Max. blade position angle	90°
Blade pitch	35°
Max. lift above ground	500 mm (19.7")
Max. cutting depth	350 mm (13.8")

SCARIFIERS

Shank holders	9 / 11
Frame width	1260/1583 mm (50"/62")
Working width	1220/1525 mm (48"/60")
Scarifying depth	250 mm (10")
Shank holder spacing	150 mm (5.9")
Weight, total	350/410 kg (772/904 lb)

BLADE EQUIPMENT, FRONT

Type of blade	DOZER	ANGLE
Blade width (A)	2500 mm (98.4")	3080 mm (121.3")
Blade height (B)	850 mm (33.5")	850 mm (33.5")
Max. lift	480 mm (18.9")	480 mm (18.9")
Cutting depth	50 mm (2")	50 mm (2")
Max. blade angle	33°	
Weight of blade equipment	700 kg (1,543 lb)	800 kg (1,764 lb)

RIPPER

Ripper width	2200 mm (87")
Width of ripping	2195 mm (86")
Ripping depth	300 mm (12")
Shank holders	3 + 6
Weight, total	1110 kg (2,447 lb)
Penetration force	12250 kg (27,006 lb)
Pryout force	11300 kg (24,912 lb)

RD-200C RD-200H MOTOR GRADERS



STANDARD EQUIPMENT

- Air cleaner, 2-stage, dry type w/service indicator
 - Air conditioner
 - Alarm, back-up
 - Alternator, 75A
 - Axles rear, planetary type
 - Batteries, (2)12 V, 120 Ah, low maintenance
 - Beacon light, rotating
 - Brakes, service: wet multidisc, hydraulic applied, two-circuit with gas accumulators, effective on four tandem wheels; parking: disc type, mounted on output shaft of the transmission
 - Cab ROPS (SAE J1040) w/sound suppression, CD radio, front and rear wipers and washers, lockable door
 - Cooling module; includes radiator, transmission and torque converter oil cooler and charge air cooler, isolation mounted
 - Differential, No Spin
 - Electrical system, 24 V
 - Extinguisher
 - Fan, hydraulically driven
 - Fenders, rear
 - Hood sides for engine compartment
 - Horn, electric
 - Hydraulic system, load sensing, 9-spool valve
 - Instrument panel
 - Lights, travelling - front and rear, turn signals
 - Lights, working, cab and radiator bonnet mounted
 - Manuals, parts and operator's
 - Mirrors, rear view, R. H. and L. H., heated
 - Moldboard, full 360° circle rotation, hydraulic sideshift and pitch
 - Monitoring and control system
 - Muffler with exhaust pipe
 - Rear door for engine and radiator compartment
 - Seat, adjustable, suspension type, with arm rests and seat belt (SAE J386)
 - Starting aid - air grid heater
 - Steering column, adjustable and tiltable
 - Steering, hydrostatic
 - Steps, left and right
 - Tires (6), 17.5 R25
 - Tool kit
 - Torque converter
 - Transmission, full powershift, 6 speeds forward and 3 reverse, electronically controlled, automatic or manual mode
- **DRIVE SYSTEMS**
RD-200C - Tandem drive
RD-200H - All-wheel drive (AWD)

OPTIONAL ATTACHMENTS

- Batteries (2)12 V, 170 Ah, maintenance free
- Blade equipment, front mounted:
 - Angle blade, 3080 mm
 - Dozer blade, 2500 mm
- Centralized lubricating system
- Fenders, front
- FOPS structure, for use with cab
- Hydraulic system, additional control valves for front and rear mounted equipment
- Open Cab ROPS, with front window only
- Ripper, heavy duty, with 3 ripper type shanks and 6 scarifier type shanks
- Scarifiers with 9 or 11 shanks, front mounted, V-type, hydraulically controlled
- Spare wheel
- Tires 14.00 - 24 S29 24PR, rock application

Specifications subject to change without notice. Illustrations and pictures may include optional equipment and may not include all standard equipment.

DRESSTA Co.Ltd.

Kwiatkowskiego 1, 37-450 Stalowa Wola, POLAND
tel. +48 (15) 813 5252, 813 4556 fax: +48 (15) 844 4714
www.dressta.com.pl